

Subject: UNUSUAL NOISE WHEN STARTING TO MOVE VEHICLE WHILE STEERING WHEEL IS TURNED TO FULL LEFT POSITION	Bulletin No: 06-002/14
	Last Issued: 07/29/2014

BULLETIN NOTE

- This bulletin supersedes the previous bulletin 06-002/13, issued on 10/09/13. The APPLICABLE MODEL(S)/VINS, DESCRIPTION, REPAIR PROCEDURE, PART(S) and WARRANTY INFORMATION have been revised.
- Changes are noted below in Red beside the change bar.

APPLICABLE MODEL(S)/VINS

2013-2014 Mazda3 vehicles with VINs lower than JM1BM*****148473 (produced Nov. 19, 2013)

2014 Mazda6 vehicles with VINs lower than JM1GJ*****159769 (produced Nov. 19, 2013)

2013-2014 CX-5 vehicles with VINs lower than JM3KE*****417235 (produced Nov. 19, 2013)

DESCRIPTION

Some vehicles may exhibit an unusual (clacking) noise from under the front of the vehicle. This noise only occurs when starting to move the vehicle while the steering wheel is turned to the full left position.

NOTE: The noise will not occur if the steering wheel is in the center or full right position.

The noise is caused when the edge of the left side inner ball joint (A) gets stuck with the steering gear housing. The following modifications have been made to eliminate the noise:

1. The shape of the inner ball joint edge has been changed.
2. Grease has been applied to the inner ball joint edge.

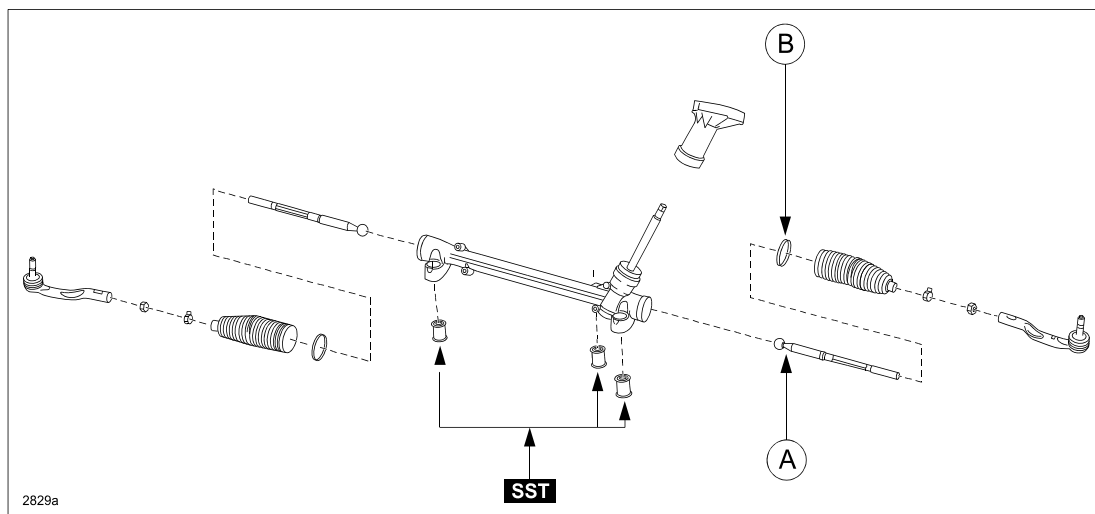

Customers having this concern should have their vehicle repaired using the following repair procedure.

CONSUMER NOTICE: The information and instructions in this bulletin are intended for use by skilled technicians. Mazda technicians utilize the proper tools/equipment and take training to correctly and safely maintain Mazda vehicles. These instructions should not be performed by "do-it-yourselfers." Customers should not assume this bulletin applies to their vehicle or that their vehicle will develop the described concern. To determine if the information applies, customers should contact their nearest authorized Mazda dealership. Mazda North American Operations reserves the right to alter the specifications and contents of this bulletin without obligation or advance notice. All rights reserved. No part of this bulletin may be reproduced in any form or by any means, electronic or mechanical---including photocopying and recording and the use of any kind of information storage and retrieval system ---without permission in writing.

REPAIR PROCEDURE

1. Verify the customer concern by turning the steering wheel full left, then start moving the vehicle.
 - If the noise is not present, this service information does not apply.
 - If the noise is present, identify the model and VIN, then perform the appropriate repair according to the table below:
- **Repair Procedure A:** Inner Ball-Joint Replacement (left side)
 - **Repair Procedure B:** Grease Application to Inner Ball Joint

Model	VIN Range / Prod. Date	Action
Mazda3	Vehicles with VINs lower than JM1BM*****148473 (Prod. Date: Nov. 19, 2013)	Perform Repair Procedure B only
Mazda6	Vehicles with VINs lower than JM1GJ*****130604 (Prod. Date: Jul. 1, 2013)	Perform Repair Procedure A only
Mazda6	Vehicles with VINs between JM1GJ*****130605 to 159769 (Prod. Date: Nov. 19, 2013)	Perform Repair Procedure B only
CX-5	Vehicles with VINs lower than JM3KE*****369145 (Prod. Date: Jul. 3, 2013)	Perform Repair Procedure A only
CX-5	Vehicles with VINs between JM3KE*****369146 to 417235 (Prod. Date: Nov. 19, 2013)	Perform Repair Procedure B only

REPAIR PROCEDURE A

1. Remove the steering gear and linkage according to the on-line instructions on MS3 or the Workshop Manual (section 06-13 STEERING GEAR AND LINKAGE REMOVAL).
2. Replace the left inner ball joint according to the on-line instructions on MS3 or the Workshop Manual (section 06-13 STEERING GEAR AND LINKAGE DISASSEMBLY).
3. Apply grease to the inner ball joint edge according to **Grease Application Procedure** below.
4. Reinstall the boot and outer ball joint to the steering gear and linkage.
5. Reinstall the steering gear and linkage in the reverse order of removal.
6. Verify the repair.

REPAIR PROCEDURE B

1. Remove the steering gear and linkage according to the on-line instructions on MS3 or the Workshop Manual (section 06-13 STEERING GEAR AND LINKAGE REMOVAL).
2. Remove the wire clamp of the boot (driver-side) and move the boot to expose the inner ball joint edge.
3. Apply grease to the inner ball joint edge according to **Grease Application Procedure** below.
4. Reinstall the boot and new wire clamp to the original position.
5. Reinstall the steering gear and linkage in the reverse order of removal.
6. Verify the repair.

Grease Application Procedure:

1. Squeeze approx. 1cc of grease out of the tube onto your finger.

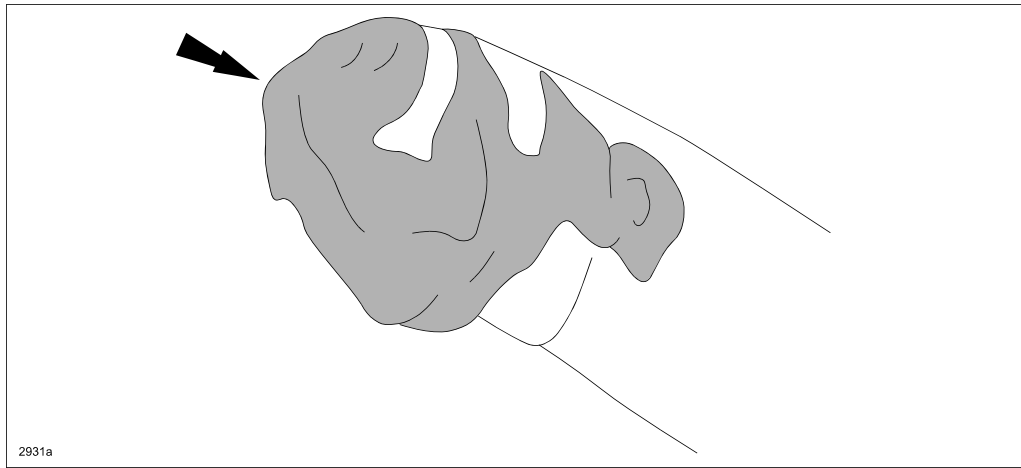

2. Apply the grease all the way around the inner ball joint edge.

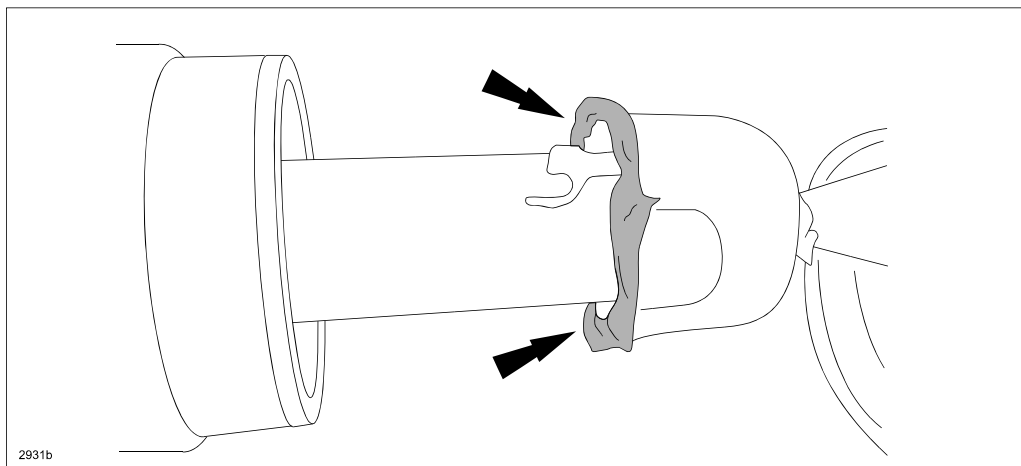

PART(S) INFORMATION

Part Number	Description	Qty.	Notes
GHT2-32-240A	Inner Ball Joint	1	Mazda6
KD31-32-240A	Inner Ball Joint	1	CX-5
BBM4-32-127	Wire Clamp	1	(B) (Replace part / See illustration)
B455-32-099B	Joint Bolt	1	Mazda6 and CX-5
KD31-32-099	Joint Bolt	1	Mazda3
T060-26-169A	Snap Pin	2	Replace part
BHY1-32-GR1	Grease	1	One (1) tube repairs twenty (20) vehicles

WARRANTY INFORMATION

NOTE:

- This warranty information applies only to verified customer complaints on vehicles eligible for warranty repair.
- This repair will be covered under the New Vehicle Limited Warranty term.
- Additional diagnostic time cannot be claimed for this repair.

Model: Mazda3:	Dealer Sublets Wheel Alignment	Dealer Performs Wheel Alignment
Warranty Type	A	A
Symptom Code	82	82
Damage Code	9M	9M
Part Number Main Cause	GHT2-32-240A	GHT2-32-240A
Quantity	0	0
Operation Number / Labor Hours	Repair Procedure B XXK7ATRX / 1.7 Hrs.	Repair Procedure B XXK7AURX / 2.6 Hrs. (Includes: Front wheel alignment check and adjust)
Sublet Code	C1	---

Model: Mazda6:	Dealer Sublets Wheel Alignment	Dealer Performs Wheel Alignment
Warranty Type	A	A
Symptom Code	82	82
Damage Code	9M	9M
Part Number Main Cause	GHT2-32-240A	GHT2-32-240A
Quantity	1 (Repair Procedure A) 0 (Repair Procedure B)	1 (Repair Procedure A) 0 (Repair Procedure B)
Operation Number / Labor Hours	Repair Procedure A XXK7AGRX / 1.8 Hrs.	Repair Procedure A XXK7AJRX / 2.7 Hrs. (Includes: Front wheel alignment check and adjust)
	Repair Procedure B XXK7AHRX / 1.7 Hrs.	Repair Procedure B XXK7AKRX / 2.6 Hrs. (Includes: Front wheel alignment check and adjust)
Sublet Code	C1	---

Model: CX-5	Dealer Sublets Wheel Alignment	Dealer Performs Wheel Alignment
Warranty Type	A	A
Symptom Code	82	82
Damage Code	9M	9M
Part Number Main Cause	KD31-32-240A	KD31-32-240A
Quantity	1 (Repair Procedure A) 0 (Repair Procedure B)	1 (Repair Procedure A) 0 (Repair Procedure B)
Operation Number / Labor Hours	Repair Procedure A (2WD) XXK7ALRX / 2.0 Hrs.	Repair Procedure A (2WD) XXK7APRX / 2.9 Hrs. (Includes: Front wheel alignment check and adjust)
	Repair Procedure A (4WD) XXK7AMRX / 1.9 Hrs.	Repair Procedure A (4WD) XXK7ARRX / 2.8 Hrs. (Includes: Front wheel alignment check and adjust)
	Repair Procedure B XXK7ANRX / 1.8 Hrs.	Repair Procedure B XXK7ASRX / 2.7 Hrs. (Includes: Front wheel alignment check and adjust)
Sublet Code	C1	---

NOTE:

- Vehicles applicable to “Repair Procedure A” require replacement of the left inner ball joint and must be claimed.
- Vehicles applicable to “Repair Procedure B” already have a modified inner ball joint installed. Replacement of the inner ball joint will not be accepted.